

CR-310 Cone Rounder



...a high degree of flexibility with regard...



Glimek CR-310 is the optimum machine for pre-rounding as well as final round moulding. The CR-310's patented centrally adjustable rounding tracks enable a high flexibility regard to type of products, weight range and capacity.



Sveba Dahlen Group



Scandinavian know-how – worldwide

CR-310 Cone Rounder

Flour duster (option) easy to remove for cleaning

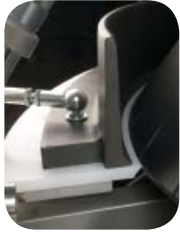

The laminated baseplates are machined to fit the cone for minimum dough loss

Rounding length up to 13ft



Reference scale for the weight range 1,05 oz - 63,5 oz



Patented system of centrally adjustable tracks

Non-stick coating on tracks for ultimate rounding. CR310GM version: Non-stick coating also on the cone

Accessories

| | |
|---|--|
| Flour duster | Flour duster, mechanical mounted on the outfeed |
| Hot and cold air blowing unit | Air blowing on the cone to assure the handling of sticky dough. 2.8 kW |
| GM-version | Glim Metallic non-stick coating on cone |
| Oiling device | Photocell controlled oiling system with 3 spraying nozzles spraying on the products. (An alternative to Hot and cold air blowing unit) |
| Outfeed cone | Small driven upside down cone to ensure transfer of sticky dough from last track onto the outfeed conveyor |
| Outfeed conveyor including transfer roller | Replaces the outfeed chute. L = 23 1/16" with separate motor drive 0.09 kW |
| Stainless steel version | Stainless steel frame and covers |
| Variable cone speed | Frequency controlled drive with speed regulator on the machine head, 1.5 kW, 18-73 rpm (Standard is 46 rpm) |
| Variable cone speed including hot and cold air blowing unit | Frequency controlled drive with speed regulator on the machine head, 2.8 kW, 18-73 rpm (Standard is 46 rpm) Airblowing on the cone to assure the handling of sticky dough |

Technical data

| | |
|-------------------------------|---|
| Capacity range | up to 3600 dough pieces/hour |
| Weight range | 1 oz - 4 lb |
| Power supply | 1.5 kW |
| Weight, net | 1015 lb |
| Weight, gross (carton+pallet) | 1300 lb |
| Volume, gross | 4.5 x 4.4 x 5.5 = 108.9 ft ³ |

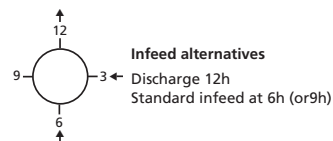
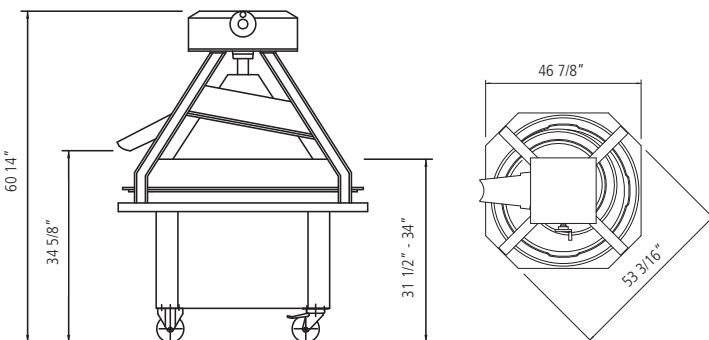

Glimmek AB
 Box 124
 S-280 64 GLIMÅKRA
 Sweden
 Tel. int. +46-(0)44 449 00 • Fax +46-(0)44 449 10
 e-mail: office@glimmek.se • www.glimmek.se



Belshaw Adamatic Bakery Group
 814 44th St NW
 Suite 103
 Auburn Washington 98001
 USA
 Phone: +1 732 544 8400
 Fax: +1 732 544 0735